

GENERAC

The Reliable Ones

2000PSI

Pressure Washer Owner's Manual

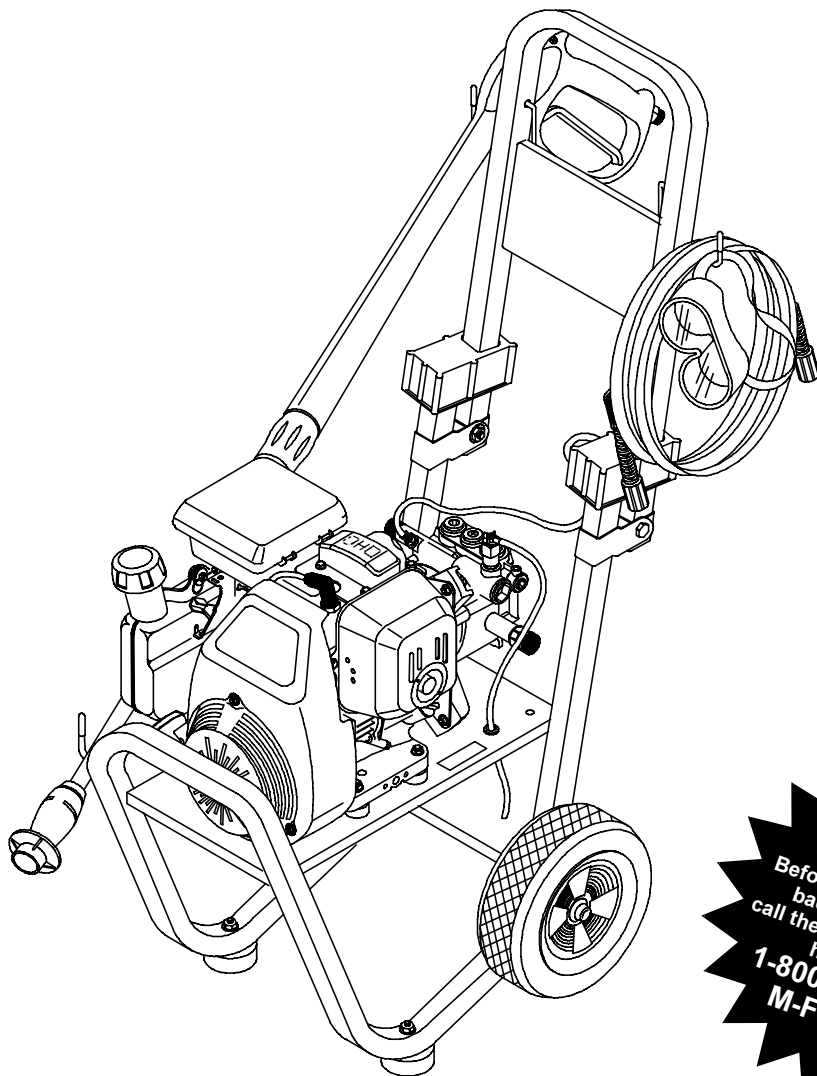

Model No. 1330-0 (2000 psi High Pressure Washer) Manual No. B4319 Revision 1 (4/28/1999)



This symbol points out important safety instructions, which, if not followed, could endanger the personal safety and/or property of yourself and others. Read and follow all instructions in the manual before attempting to operate this unit.



IMPORTANT! — SAFETY RULES — IMPORTANT!



WARNING:



The engine exhaust from this product contains chemicals known to the State of California to cause cancer, birth defects, or other reproductive harm.



CAUTION! Always disconnect spark plug wire and place wire where it cannot contact spark plug to prevent accidental starting when setting up, transporting, adjusting or making repairs to your high pressure washer.

- Engine exhaust gases contain DEADLY carbon monoxide gas. This dangerous gas, if breathed in sufficient concentrations, can cause unconsciousness or even death. Operate this equipment only in the open air where adequate ventilation is available.
- Gasoline is highly FLAMMABLE and its vapors are EXPLOSIVE. Do not permit smoking, open flames, sparks or heat in the vicinity while handling gasoline. Avoid spilling gasoline on a hot engine. Allow unit to cool for 2 minutes before refueling. Comply with all laws regulating storage and handling of gasoline.
- Locate this pressure washer in areas away from combustible materials, combustible fumes or dust.
- The high pressure equipment is designed to be used with Generac authorized parts only. If you use this equipment with parts that do not comply with minimum specifications, the user assumes all risks and liabilities.
- Some chemicals or detergents may be harmful if inhaled or ingested, causing severe nausea, fainting or poisoning. The harmful elements may cause property damage or severe injury.
- Do not allow CHILDREN to operate the pressure washer at any time.
- Operate engine only at governed speed. Running the engine at excessive speeds increases the hazard of personal injury. Do not tamper with parts which may increase or decrease the governed speed.
- Do not wear loose clothing, jewelry or anything that may be caught in the starter or other rotating parts.
- Before starting the pressure washer in cold weather, check all parts of the equipment and be sure ice has not formed there.
- Units with broken or missing parts, or without protective housing or covers should NEVER be operated.
- The muffler and air cleaner must be installed and in good condition before operating the pressure washer. These components act as spark arrestors if the engine backfires.
- Check the fuel system for leaks or signs of deterioration such as chafed or spongy hose, loose or missing clamps or damaged tank or cap. Correct all defects before operating the pressure washer.
- Do not spray flammable liquids.
- Never aim the gun at people, animals or plants.

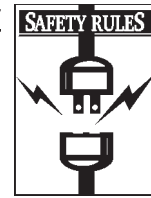

IMPORTANT! — SAFETY RULES — IMPORTANT!

- High pressure spray can cause paint chips or other particles to become airborne and fly at high speeds.
- Never allow any part of the body to come in contact with the fluid stream. DO NOT come in contact with a fluid stream created by a leak in the high pressure hose.
- The high pressure stream of water that this equipment produces can pierce skin and its underlying tissues, leading to serious injury and possible amputation.
- Always wear eye protection when you use this equipment or when you are in the vicinity where the equipment is in use.
- Do not operate the pressure washer above the rated pressure.
- Never move the machine by pulling on the high pressure hose. Use the handle provided on the top of the unit.
- Always be certain the spray gun, nozzles and accessories are correctly attached.
- Never use a spray gun which does not have a trigger lock or trigger guard in place and in working order.
- Use a respirator or mask whenever there is a chance that vapors may be inhaled. Read all instructions with mask so you are certain the mask will provide the necessary protection against inhaling harmful vapors.
- High pressure spray may damage fragile items including glass. Do not point spray gun at glass when in the jet spray mode.
- Keep the hose connected to machine or the spray gun while the system is pressurized. Disconnecting the hose while the unit is pressurized is dangerous.
- Hold the spray gun firmly in your hand before you start the unit. Failure to do so could result in an injury from a whipping spray gun. Do not leave the spray gun unattended while the machine is running.
- The cleaning area should have adequate slopes and drainage to reduce the possibility of a fall due to slippery surfaces.
- Keep water spray away from electric wiring or fatal electric shock may result.
- Do not secure the spray gun in the (open) position.
- Do not by-pass any safety device on this machine.
- The muffler and engine heat up during operation and remain hot immediately after shutting it down. Avoid contact with a hot muffler or engine or you could be severely burned.
- Operate and store this unit on a stable surface.
- High pressure hose can develop leaks from wear, kinking, abuse, etc. Water spraying from a leak is capable of injecting material into skin. Inspect hose each time before using it. Check all hoses for cuts, leaks, abrasions or bulging of cover, or damage or movement of couplings. If any of these conditions exist, replace hose immediately. Never repair high pressure hose. Replace it with another hose that meets maximum pressure rating of your pressure washer.



CONGRATULATIONS on your purchase of a GENERAC high pressure washer. It has been designed, engineered and manufactured to give you the best possible dependability and performance.

Should you experience any problem you cannot easily remedy, call the pressure washer helpline at 1-800-270-1408.

Please read and retain this manual. The instructions will enable you to assemble and maintain your high pressure washer properly.

CUSTOMER RESPONSIBILITIES

- Read and observe the safety rules.
- Follow regular schedule in maintaining, caring for and using your high pressure washer.
- Follow the instructions under “Customer Responsibilities” and “Storage” sections of this Owner's Manual.

| | |
|-------------------------|---------------|
| Model Number | 1330-0 |
| Serial Number | _____ |
| Date of Purchase | _____ |

The model and serial numbers will be found on a decal attached to the pressure washer. Record both serial number and date of purchase and keep in a safe place for future reference.

PRODUCT SPECIFICATIONS

Pressure Washer Specifications

- Outlet Pressure** 2000 psi
- Flow Rate** 2.0 gallons per minute (gpm)
- Detergent** Use detergent approved for pressure washers
- Water Supply Temperature** Not to Exceed 140°F
- Automatic Cool Down System** Will cycle when water reaches 140°-145°F

Engine Specifications

- Engine Model** Honda GC 160
- Rated Horsepower** . . . 5 HP
- Displacement** 160 cc
- Spark Plug**
- Type** BPR6ES (NGK)
- Set Gap To:** . . . 028-.031 inch (.7-.8mm)
- Gasoline Capacity**53 U.S.gallons (2.0l)
- Oil** See page 7

In the State of California a spark arrestor is required by law (Section 4442 of the California Public Resources Code). Other states may have similar laws. Federal laws apply on federal lands.

NOTE: If you equip the muffler with a spark arrestor, it must be maintained in effective working order.

You can order a spark arrestor through your authorized Honda service dealer.



KNOW YOUR PRESSURE WASHER

Read this owner's manual and safety rules before operating your high pressure washer.

Compare the illustrations with your high pressure washer to familiarize yourself with the location of the controls. Save this manual for future reference.

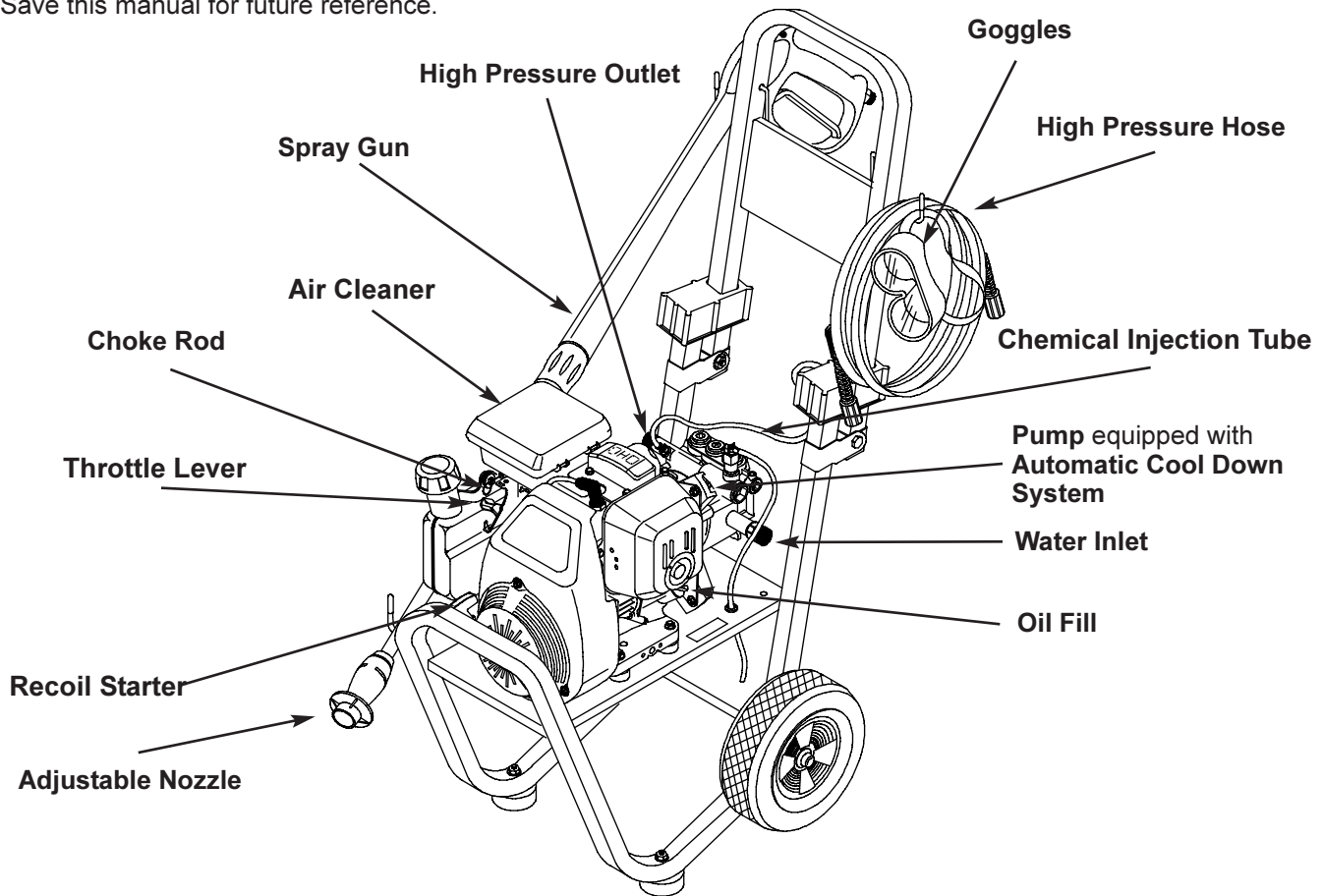

Adjustable Nozzle — You must attach this to the spray gun to provide high pressure stream. Adjustable nozzle allows you to adjust force of spray and spray pattern.

Air Cleaner — Dry type filter element limits the amount of dirt and dust that gets in the engine.

Automatic Cool Down System — Cycles water through pump when water reaches 140°-145°F. **Warm water will discharge from pump onto ground.** This system prevents internal pump damage.

Chemical Injection Tube—Used to siphon chemical from the detergent container to the pump.

Choke Rod— Prepares a cold engine for starting.

Goggles — Always use the enclosed goggles or other eye protection when running your pressure washer.

High Pressure Hose — Connect one end to water pump and the other end to spray gun.

High Pressure Outlet — Connection for high pressure hose.

Oil Fill—Oil input location.

Pump — Develops high pressure.

Recoil Starter — Used for starting the engine manually.

Spray Gun — Controls the application of water onto cleaning surface with trigger device. Includes safety latch.

Throttle Lever—Sets engine in starting mode for recoil starter and stops a running engine.

Water Inlet — Connection for garden hose.

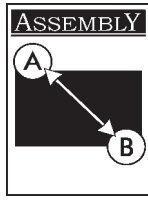

WARNING! Read entire owner's manual before you attempt to assemble or operate your new pressure washer.

REMOVE PRESSURE WASHER FROM CARTON

- Remove the high pressure hose and parts box included with pressure washer.
- Slice two corners at the end of carton from top to bottom so the panel can be folded down flat, then remove all packing material.
- Roll pressure washer out of carton.

CARTON CONTENTS

Items in the carton include:

- Main Unit
- High Pressure Hose
- Parts Box (includes the following):
 - Oil Bottle
 - Wire Form
 - Goggles
 - Nozzle Cleaning Kit
 - O-Ring Maintenance Kit
 - Owner's Manual
 - Engine Manual
 - Engine Warranty
 - Emissions Control Warranty
 - Warranty Card
 - Spray Gun
 - Adjustable Nozzle Extension

If any of the above parts are missing or damaged, call the pressure washer helpline at **1-800-270-1408**.

PREPARING PRESSURE WASHER FOR USE

If you have any problems with the assembly of your pressure washer or if parts are missing or damaged, call the Pressure Washer Helpline at **1-800-270-1408**.

To prepare your pressure washer for operation you will need to perform these tasks:

- Unfold the handle and attach the wire form.
- Add oil to the engine.
- Add fuel to the fuel tank.
- Connect the high pressure hose to the spray gun and the pump.
- Connect the water supply to the pump.
- Connect nozzle extension to gun.

Secure Handle and Wire Form

- Lift handle and slide locking caps over the bottom part of the handle (Figure 1).

Figure 1 — Secure Handle

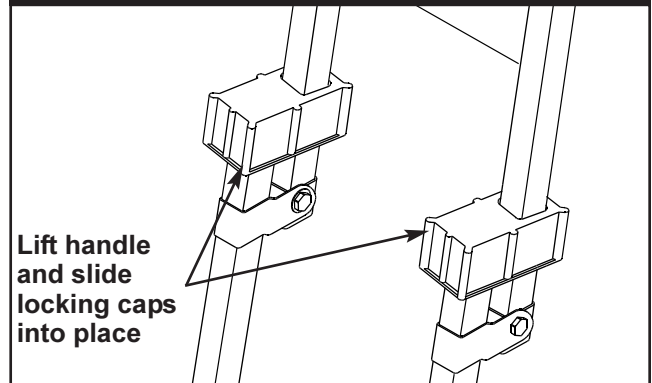

- Insert wire form into the handle with the longer arm positioned on the left. From rear of unit, the hook should resemble a "J" (Figure 2).

Figure 2 — Attach Wire Form to Handle

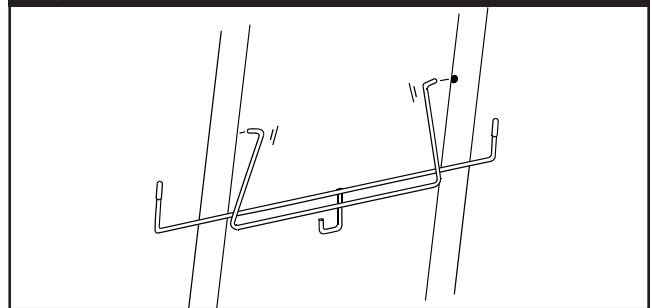

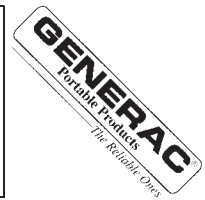
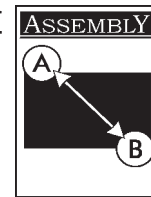

Add Engine Oil

WARNING! Any attempt to crank or start the engine before it has been properly serviced with the recommended oil will result in an engine failure.

Use only high quality detergent oil rated with API service classification SF or SG rated 10W30. Do not use SAE 10W40 oil. Other viscosities shown in the chart below may be used when the average temperature in your area is within the recommended range.

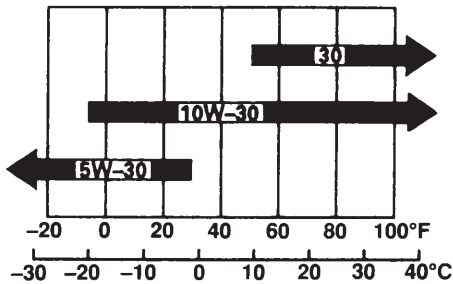

- Place the pressure washer on a level surface.
- Clean the area around oil fill and remove the oil dipstick (Figure 3).

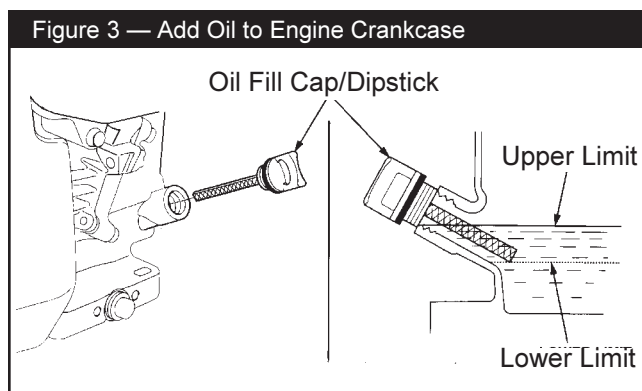

- Wipe the dipstick clean.
- Insert and remove the dipstick without screwing it into the filler neck. Check the oil level shown on the dipstick.

- If the oil level is low, fill to the edge of the oil filler hole with the recommended oil. **Do not overfill.**
- Reinstall the oil dipstick, hand tighten securely.

Note: Check Oil Often During Engine Break-in.

Add Gasoline

DANGER! Never fill fuel tank indoors, or when engine is running or hot. **Do not smoke** when filling fuel tank.

WARNING! Never fill fuel tank completely full. Fill tank to about 1/2" below the bottom of the filler neck to provide space for fuel expansion. Wipe away any fuel spillage from engine and equipment before starting.

- Use clean fuel and store in approved, clean covered containers. Use clean fill funnels. Never use "stale" gasoline left over from last season or gasoline stored for long periods.
- Clean the area around the fuel fill cap, remove the cap (Figure 4).

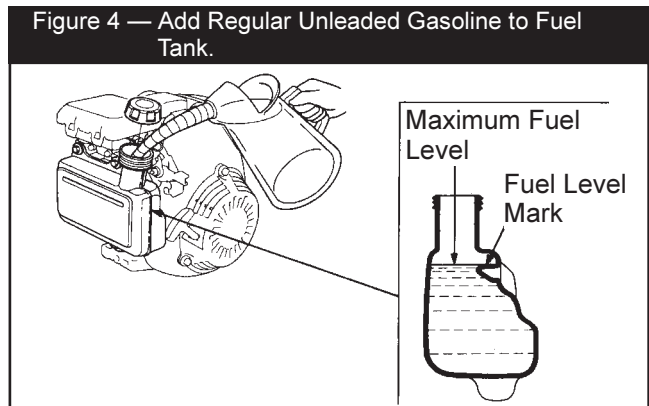

- Add **regular UNLEADED gasoline**, slowly, to fuel tank. Use a funnel to prevent spillage.
- Install the fuel cap and wipe up any spilled gasoline.

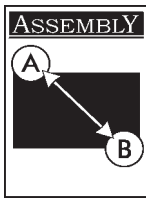

Connect Hose and Water to Pump

IMPORTANT: You must assemble the wand and attach all hoses before you start the engine. Starting engine without all hoses connected and water supplied will damage the pump.

- Uncoil the high pressure hose and attach one end of the hose to the base of the spray gun. (Figure 5). Tighten by hand.

Figure 5 — Connect High Pressure Hose to Spray Gun

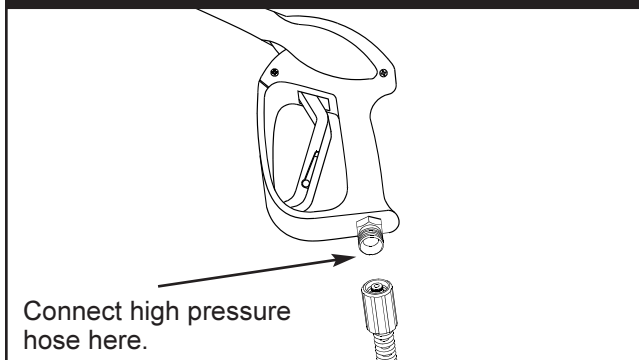

- Attach the other end of the high pressure hose to the high pressure outlet on the pump (Figure 6). Tighten by hand.

Figure 6 — Connect High Pressure Hose to Pump

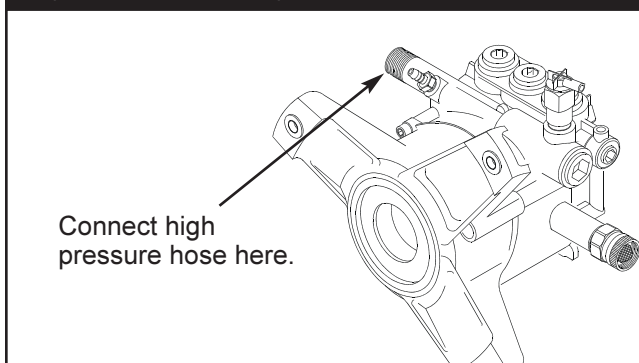

- Before you connect your garden hose to the water inlet, inspect the Inlet Screen (Figure 7). Clean the screen if it contains debris or have it replaced if damaged. **DO NOT RUN THE PRESSURE WASHER IF THE SCREEN IS DAMAGED.**

Figure 7 — Connect the Garden Hose to Water Inlet and Turn ON the Water.

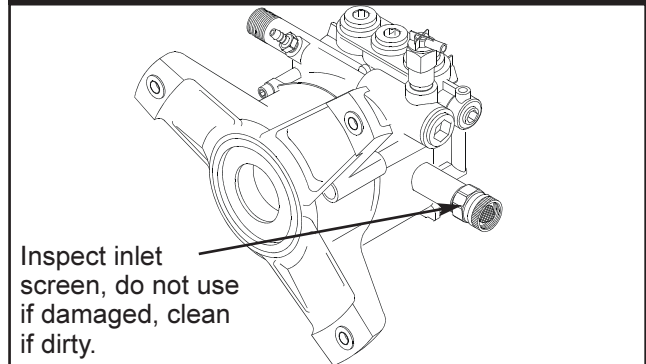

- Run water through your garden hose for 30 seconds to clean out any debris .
- Connect the garden hose to the water inlet. Tighten by hand (Figure 7).
- Turn ON the water.
- Squeeze the trigger on the gun until you have a steady stream of water. This purges the pump system of air and impurities.



CAUTION: Before starting the pressure washer, be sure you are wearing adequate eye protection.

- Attach the adjustable nozzle extension to the spray gun. Tighten by hand (Figure 8).

Figure 8 — Connect Nozzle Extension to Spray Gun

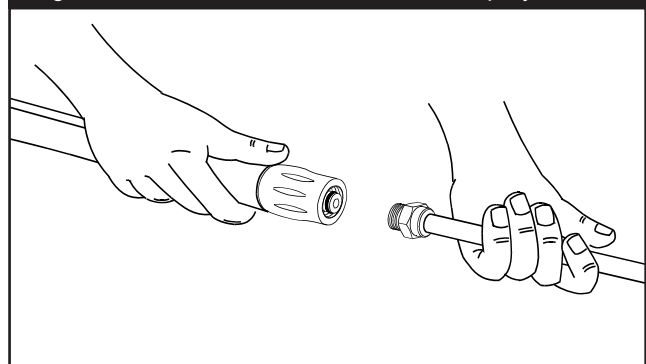



CHECKLIST BEFORE STARTING ENGINE

If you have reached this point, look back over the assembly to see if you have performed all of the following.

- Make sure the handle and wireform are in place and secure.
- Check for properly tightened hose connections (high pressure and water supply).
- Check to make sure that there are no kinks, cuts, or damage to the high pressure hose.
- Check that oil has been added to the proper level in the engine crankcase before trying to start the pressure washer.
- Add the proper gasoline to fuel tank.
- Provide a proper water supply (not to exceed 140°F).
- Be sure to read the “Safety Rules” and “Operation” sections before using the pressure washer.

HOW TO USE YOUR PRESSURE WASHER

If you have any problems operating your pressure washer, please call the pressure washer helpline at 1-800-270-1408.

How to Start Your Engine

The best way to start your engine-powered pressure washer for the first time is to follow these instructions step-by-step. This starting information also applies whenever you start the engine after you have let the pressure washer sit idle for at least a day.

- Place the pressure washer in an area close enough to an outside water source that can flow at a rate of 2.2 gallons per minute.
- Make sure the unit is in a level position.
- Check that the high pressure hose is tightly connected to the spray gun and to the pump.
- Connect the garden hose to the water inlet on the pressure washer pump and **turn on the water**.



WARNING! Do not run the pump without the water supply connected and turned on. You must follow this caution or the pump will be damaged.

- Position the nozzle in the low pressure mode (nozzle slid forward) and squeeze the trigger on the spray gun to relieve the air pressure caused by turning ON the water. Water will flow out of the gun in a thin stream. Continue to hold trigger until you have a steady stream of water and no air remains in the system. This will make it easier to pull start the engine. Release the trigger.
- Engage the safety latch on the spray gun (Figure 9).

Figure 9 — Spray Gun with Safety Latch Engaged

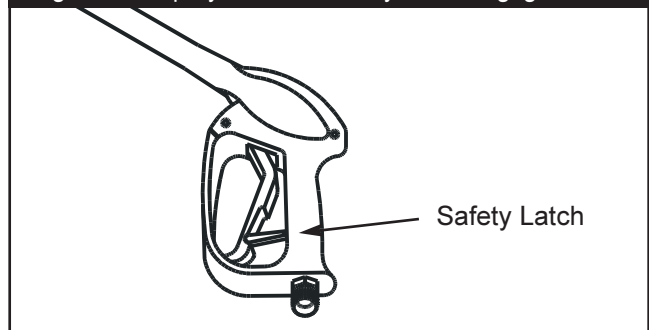



- Position the choke rod (Figure 10).

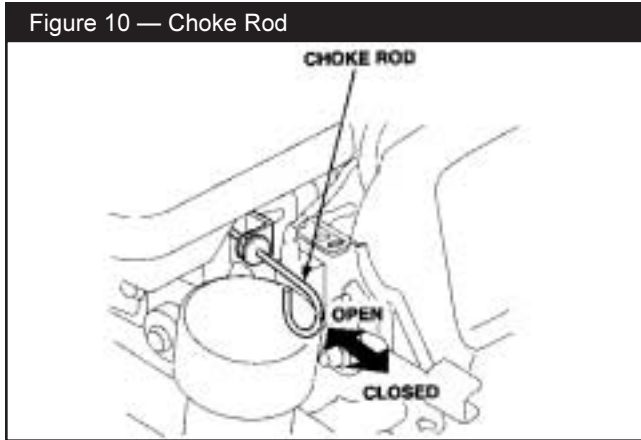

- Cold engine ~ ~ ~ ~ ~ (Choke-CLOSED)
- Restarted warm engine ~ ~ ~ ~ (Choke-OPEN)
- Just refueled engine ~ ~ ~ ~ (Choke-CLOSED)
- Move throttle lever to the “Fast” position (Figure 11).

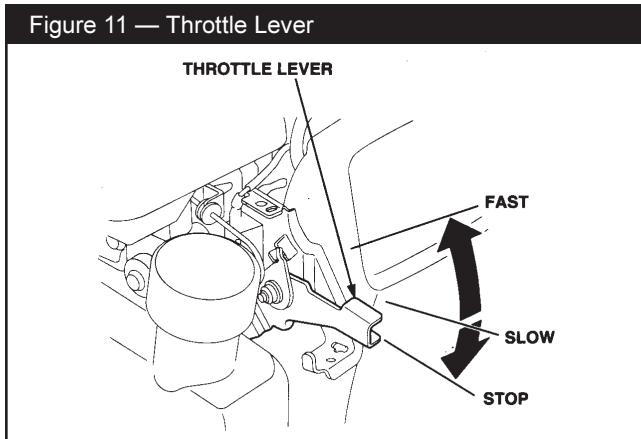

IMPORTANT: When using the pressure washer, always keep the throttle in the fast position.

- Grasp the starter grip handle and pull slowly until you feel some resistance. Then pull rapidly to start the engine (Figure 12).

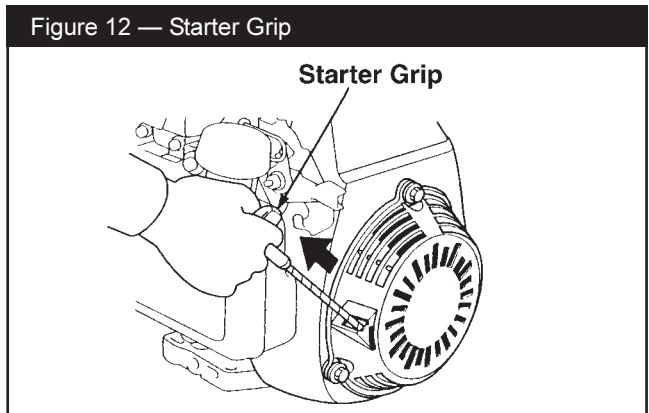

- Return the starter grip handle slowly.
- Grasp starter grip and pull slowly until you feel some resistance. Then pull cord out with rapid full arm stroke. Let rope return slowly. Do not let rope “snap back” against starter.
- If the choke lever has been moved to the “CLOSED” position to start the engine, gradually move it to the “OPEN” position as the engine warms up.

How to Stop Your Pressure Washer

- Move the throttle Lever to the “Stop” position.
- **Squeeze trigger on the spray gun to relieve pressure in the hose.**

Note: A small amount of water will squirt out from the spray gun when you release the pressure.



How to Use the Adjustable Nozzle

You now should know how to **START** your pressure washer and how to **STOP** it. The information in this section will tell you how to adjust the spray pattern and apply detergent or any other cleaning chemicals.

! DANGER! Never adjust spray pattern when spraying. Never put hands in front of nozzle to adjust spray pattern.

On the end of your spray gun is a nozzle that you can slide forward and backward and that you can also twist from side to side. With the adjustable nozzle you can adjust the spray pattern to be either high pressure or low pressure. You can also adjust the spray so it is concentrated in a stream pattern or expanded into a fan pattern.

- Slide the nozzle forward when you wish to adjust the spray to low pressure mode (Figure 13). Slide the nozzle backward to achieve high pressure.
- Point the nozzle toward the ground and press the trigger to test the pattern (Figure 14).
- Twisting the nozzle adjusts the spray pattern from a narrow pattern to a fan pattern.

Figure 14— Testing the spray pattern.



- For most effective cleaning, keep spray nozzle between 8 to 24 inches away from cleaning surface.
- If you get the spray nozzle too close, especially using high pressure mode, you may damage the cleaning surface.
- Do not get closer than 6 inches when cleaning automobile tires.

Figure 13 — Using the adjustable nozzle.

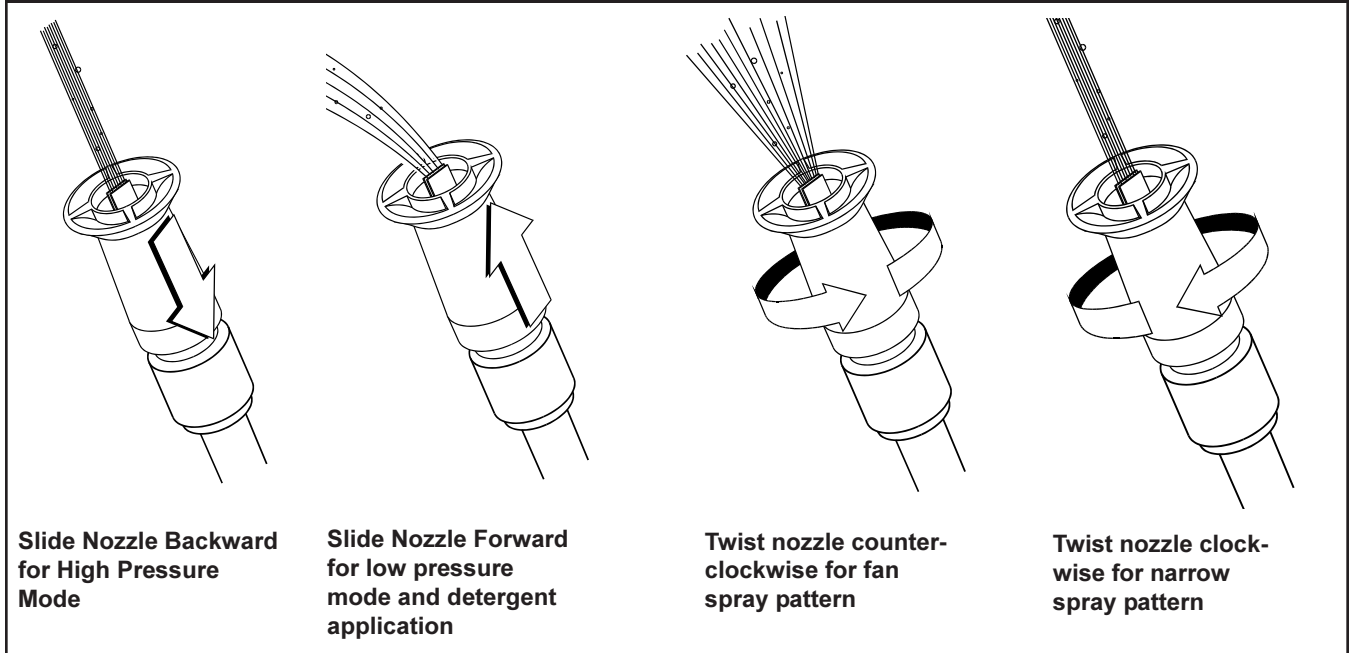



Applying Detergent with the Adjustable Nozzle

IMPORTANT: Use soaps designed specifically for pressure washers. Household detergents could damage the pump.

IMPORTANT: You must **attach all hoses** before you start the engine. Starting the engine without all the hoses connected and without the water turned ON will damage the pump.

To apply detergent follow these steps:

- Review the use of adjustable nozzles on page 11.
- Prepare the detergent solution as required by the job.
- Hang the detergent solution on hook of the wireform on the handle (Figure 15).

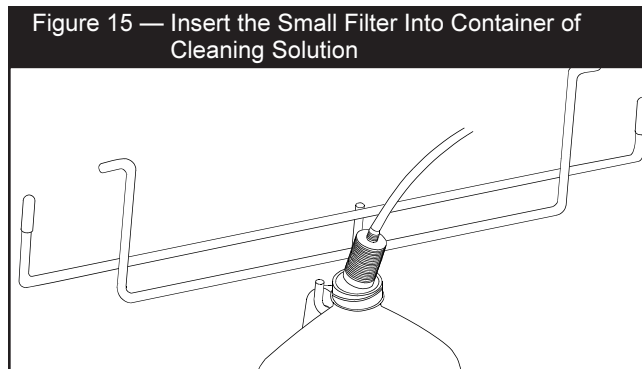

- Place small filter of the clear, detergent siphoning tube into the detergent container.

CAUTION! Keep the plastic injector tube from coming in contact with the hot muffler. This will damage the plastic tube. When inserting the filter into a cleaning agent bottle, route the tube so as to keep it from inadvertently contacting the hot muffler.

- Slide the adjustable nozzle forward to low pressure mode. Detergent cannot be applied with nozzle in high pressure position.

IMPORTANT: Detergent cannot be applied without the water source turned on.

- Make sure garden hose is connected to water inlet. Check that high pressure hose is connected to spray gun and pump. Start engine.

- Apply detergent to a dry surface, starting from the bottom and working up.
- Allow the detergent to soak in between 3-5 minutes before washing and rinsing.
- For washing, start at lower portion of area to be washed and work upward, using long, even overlapping strokes.

Pressure Washer Rinsing

WARNING: Be extremely careful if you must use the pressure washer from a ladder, scaffolding or any other relatively unstable location. Pressure in a running washer builds as you climb. When you press the trigger, the recoil from the initial spray could force you to fall. The high pressure spray could also force you to fall if you are too close to the cleaning surface.

For Rinsing:

- Slide nozzle backward to high pressure and wait for detergent to clear.
- Keep the spray gun a safe distance from the area you plan to spray.
- Apply a high pressure spray to an small area and then check the surface for damage. If no damage is found, you can assume it is okay to continue cleaning.
- Start at top of area to be rinsed, working down with same overlapping strokes as you used for cleaning.

Note: You can also stop detergent from flowing by simply removing siphon from bottle.

Automatic Cool Down System (also known as Thermal Relief)

If you run the engine on your pressure washer for 3-5 minutes without pressing the trigger on the spray gun, circulating water in the pump can reach a temperature between 140–145°F. When the water reaches this temperature, the automatic cool down system engages and cools the pump by **discharging the warm water onto the ground**. This system prevents internal damage to the pump.

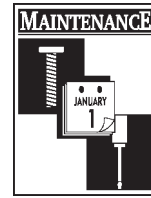

GENERAL MAINTENANCE RECOMMENDATIONS

The warranty of the high pressure washer does not cover items that have been subjected to operator abuse or negligence. To receive the full value from the warranty, the operator must maintain the high pressure washer as instructed in this manual.

- Some adjustments will need to be made periodically to properly maintain your high pressure washer.
- All adjustments in the Service and Adjustments section of this manual should be made at least once each season.
- Once a year you should clean or replace the spark plug and clean or replace the air filter and check the gun and wand assembly for wear. A new spark plug and clean air filter assure proper fuel–air mixture and help your engine run better and last longer.

Before Each Use

- Check engine oil level.
- Check water inlet screen for damage.
- Check high pressure hose for leaks.
- Check chemical injection tube and filter for damage.
- Check gun and adjustable nozzle extension assembly for leaks.
- Rinse out garden hose to flush out debris.

PRESSURE WASHER MAINTENANCE

Check and Clean Inlet Screen

Examine the screen on the water inlet. Clean it if the screen is clogged or replace it if screen is damaged.

Check High Pressure Hose

The high pressure hose can develop leaks from wear, kinking, or abuse. Inspect the hose each time before using it. Check for cuts, leaks, abrasions or bulging of cover, damage or movement of couplings. If any of these conditions exist, replace the hose immediately.



DANGER! Water spraying from a leak is capable of injecting material into skin. Inspect hose each time before using it. Never repair a high pressure hose. Replace it with another hose that meets the maximum pressure rating of your pressure washer.

Check Gun and Adjustable Nozzle Extension

Examine the hose connection to the gun and make sure it is secure. Test the trigger by pressing it and making sure it springs back into place when you release it. Put the safety latch in the ON position and test the trigger. You should not be able to press the trigger.

Check In-Line Filter

Refer to Figure 16 and service the in-line filter if it becomes clogged, as follows:

Figure 16 — Service In-Line Filter

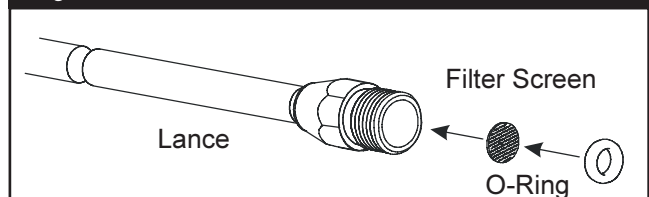

1. Detach gun and lance from high pressure hose. Detach lance from gun and remove o-ring and screen from lance. Flush the screen, gun, and lance with clean water to clear debris.
2. If the screen is damaged, the o-ring kit contains a replacement in-line filter screen and an o-ring. If undamaged, reuse screen.
3. Place the in-line filter screen into the threaded end of the lance. Direction does not matter. Push the screen in with the eraser end of a pencil until it rests flat at the bottom of the opening. Take care to not bend the screen.
4. Place the o-ring into the recess. Push the o-ring snugly against the in-line filter screen.
5. Assemble the lance to the spray gun, as described earlier in this manual.



Check Chemical Injection Tube

Examine the filter on the detergent hose and clean if clogged. The tube should fit tightly on the barbed fitting. Examine the tube for leaks or tears. Replace the filter or tube if either is damaged.

Purge Pump of Air and Contaminants

To remove the air from the pump, follow these steps:

- Set up the pressure washer as described in the “Preparing the Pressure Washer for Use” section and connect the water supply.
- Remove the nozzle extension from the gun.
- Pull the trigger on the gun and hold.

To remove the contaminants from the pump, follow these steps:

- Set up the pressure washer as described in the HOW TO USE YOUR PRESSURE WASHER section, and connect the water supply.
- Remove the nozzle extension from the gun.
- Start the engine according to instructions in OPERATION section.
- Squeeze the trigger on the gun and hold.
- When the water supply is steady and constant, engage the safety latch and refasten the nozzle extension.

Cleaning Chemical Injection Tube

If you have used the chemical injection tube you must flush it with clean water before stopping the engine.

- Place the chemical injection tube in a bucket full of clean water.
- Flush for 1–2 minutes.
- Shut off the engine.

Important: Simply shutting OFF engine will not release pressure in the system. **When the engine has shut down, squeeze the trigger on the gun to relieve the pressure in the hose.**

Nozzle Maintenance

If the adjustable nozzle becomes restricted or clogged with foreign materials, such as dirt, excessive pump pressure may develop. If this nozzle becomes partially clogged, it can cause a pulsing sensation during use. This generally is not a pump related problem, but rather a clogged or partially restricted adjustable nozzle.

If the adjustable nozzle becomes clogged or partially restricted, immediately clean the nozzle with the kit included with your pressure washer by following these instructions:

- Shut off the engine and turn off the water supply.
- Separate the wand extension from the gun.
- Adjust the wand extension to the stream position.
- Remove nozzle from the end of the wand extension (Figure 16) using a 2mm or 5/64 allen wrench (like the one included in the kit).
- Use the wire included in the kit (Figure 16) or a small paper clip to free the foreign materials clogging or restricting the nozzle.

Figure 16 — Remove and clean nozzle.

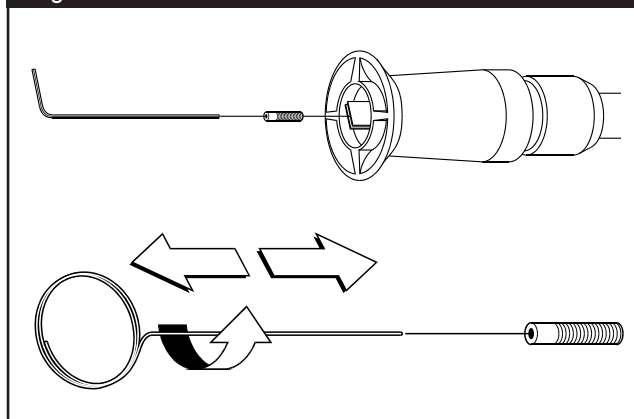

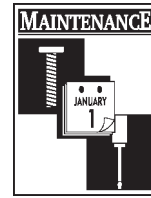

- Remove additional debris by back flushing water supply through wand extension (Figure 17). Back flush between 30 to 60 seconds. Turn wand extension to stream spray and move nozzle from low to high while flushing.

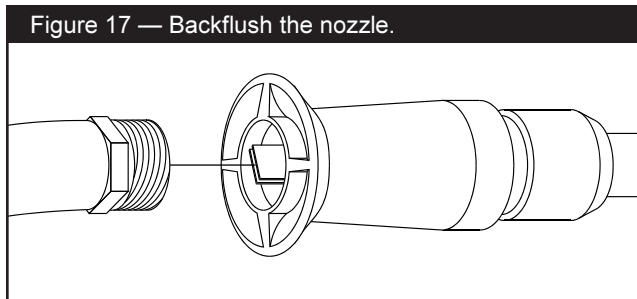

- Reinstall nozzle into the wand extension. DO NOT over tighten.
- Reconnect the wand extension to the gun.
- Reconnect the water supply, turn on the water, and start the engine.
- Test the pressure washer by operating with nozzle in the high and in the low position.

O-Ring Maintenance

Through the normal operation of your pressure washer, o-rings, which keep the connections of the hoses and gun tight and leak-free, may become worn or damaged.

Provided with your pressure washer is an O-Ring Maintenance Kit (p/n B3057) which provides replacement o-rings, rubber washer and water inlet filter.

To remove a worn or damaged o-ring:

- Use a small flathead screwdriver to get underneath the o-ring and pry it off.

ENGINE MAINTENANCE

See the Engine Owner's Manual for instructions on how to properly maintain the engine.

PREPARING UNIT FOR STORAGE

Water should not remain in the unit for long periods of time. Sediments of minerals can deposit on pump parts and "freeze" pump action. If you do not plan to use the pressure washer for more than 30 days, follow this procedure:

1. Flush chemical injection tube by placing the filter into a pail of clean water while running pressure washer in low pressure (adjustable nozzle in forward position). Flush for one to two minutes.
2. Shut off the engine and let it cool, then remove all hoses.
3. Place the throttle lever in STOP position.



WARNING! Be sure lever is in "STOP" position before you continue. If you start engine without proper water supply connected, you can damage pump.

4. Empty the pump of all pumped liquids by pulling the recoil handle about 6 times. This should remove most of the liquid in the pump.

NOTE: To protect the unit from freezing temperatures, draw RV antifreeze (no alcohol) into the pump by pouring the antifreeze into a 3-foot section of garden hose connected to inlet adapter and pulling recoil handle twice.

5. Store in a clean, dry area.

STORING THE ENGINE

See the Engine Owner's Manual for instructions on how to properly store the engine.



TROUBLESHOOTING

| Problem | Cause | Solution |
|---|--|--|
| Pump has the following problems: Failure to produce adequate pressure, erratic pressure, chattering, loss of pressure or low water volume. | <ol style="list-style-type: none"> Lance in low pressure. Water inlet is blocked. Inadequate water supply. Garden hose is kinked or leaking. Clogged water inlet screen. Water supply is over 140°F. Outlet hose is blocked or leaks. Gun leaks. Nozzle is obstructed. Pump is faulty. | <ol style="list-style-type: none"> Adjust chemical valve handle to high pressure. Clear inlet. Make sure you have at least a 2.2 GPM flow for your garden hose. Straighten garden hose or patch leak. Check and clean water inlet screen. Provide cooler water supply. Clear blocks in outlet hose. Replace immediately if leaking. Replace gun. Clear nozzle. Contact Generac service facility. |
| Detergent fails to mix with spray. | <ol style="list-style-type: none"> Chemical injector hose is not submerged. Chemical injector hose is clogged. Lance is in high pressure mode. | <ol style="list-style-type: none"> Insert chemical line into detergent. Clean or replace filter/chemical injector hose. Put dual lance into low pressure mode. |
| Engine runs well when not spraying but "bogs down" when trigger is squeezed. | Engine speed is too slow. | Contact Honda service facility. |
| Engine will not start; or starts and runs rough. | <ol style="list-style-type: none"> Low oil level. Dirty air cleaner. Out of gasoline. Stale gasoline. Spark plug wire not connected to spark plug. Bad spark plug. Water in gasoline. Excessively rich fuel mixture. Intake valve stuck open or closed. Engine has lost compression | <ol style="list-style-type: none"> Fill crankcase to proper level. Clean or replace air filter. Fill fuel tank. Drain gas tank; fill with fresh fuel. Connect wire to spark plug. Replace spark plug. Drain as tank fill with fresh fuel. Contact Honda service facility. Contact Honda service facility. Contact Honda service facility. |
| Engine shuts down during operation. | <ol style="list-style-type: none"> Out of gasoline. Low oil level | <ol style="list-style-type: none"> Fill fuel tank. Fill crankcase to proper level. |
| Engine lacks power. | Dirty air filter. | Replace air filter. |
| Engine "hunts" or falters. | Engine is not operating properly. | Contact Honda service facility. |

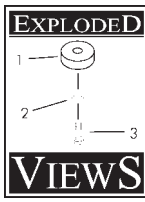

EXPLODED VIEW—MAIN UNIT

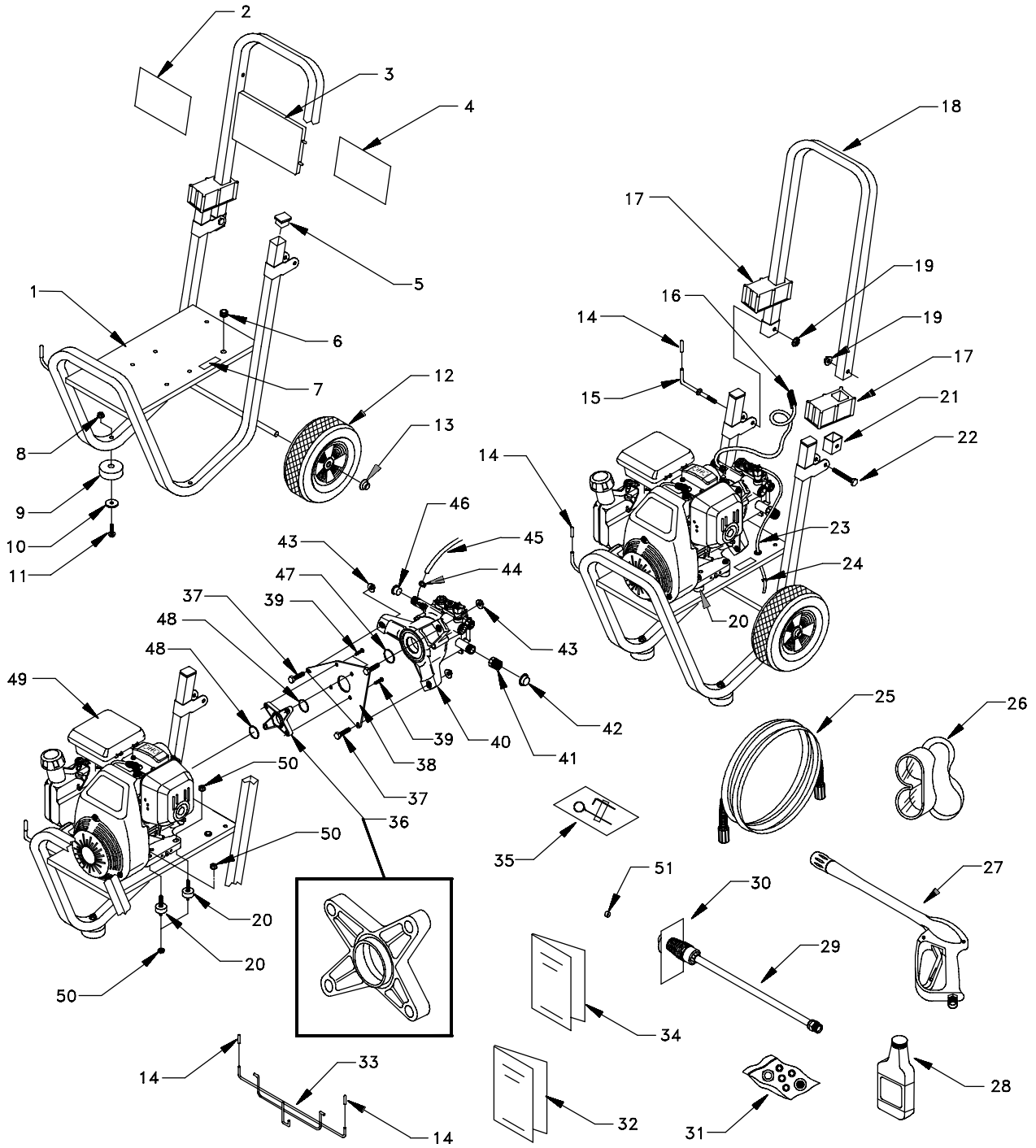

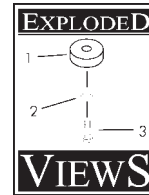

PART LIST—MAIN UNIT

| Item | Part # | Qty | Description | Item | Part # | Qty | Description |
|------|--------|-----|-----------------------------------|------|---------|-----|---------------------------------|
| 1 | AB2789 | 1 | FRAME, Weldment | 26 | 87815 | 1 | GOGGLES, Safety |
| 2 | B4324 | 1 | DECAL, 2000 PSI | 27 | B3263 | 1 | GUN, High Pressure |
| 3 | B1631A | 1 | BILLBOARD, Plastic | 28 | BB3061B | 1 | OIL, Engine |
| 4 | B2796 | 1 | DECAL, Start Instructions | 29 | B3335 | 1 | WAND, Adjustable Nozzle |
| 5 | 46476 | 2 | CAPLUG, 1 Sq. x 16 GA | 30 | 97566 | 1 | TAG, Nozzle Instruction |
| 6 | 30809 | 1 | GROMMET, 1/8" - 11/16" | 31 | B3057 | 1 | KIT, Maintenance |
| 7 | 20566 | 1 | DECAL, 1-800 # | 32 | B4319 | 1 | MANUAL, Owners 1330-0 |
| 8 | 52858 | 2 | NUT, Locking M8 1.25 | 33 | B2168 | 1 | WIREFORM |
| 9 | 27007 | 2 | VIB MOUNT, Donut Type | 34 | B3294 | 1 | MANUAL, Engine Honda |
| 10 | 50190 | 2 | FLAT WASHER, 10 GA | 35 | B2163 | 1 | KIT, Nozzle Cleaning |
| 11 | 39287 | 2 | HHCS, M8 1.25 x 45 | 36 | B2486 | 1 | ADAPTER, Engine |
| 12 | B2142 | 2 | WHEEL, Black Mag 2" x 9" | 37 | 42909 | 3 | HHCS, M8 - 1.25 x 30 |
| 13 | 75402 | 2 | PUSHNUT, 1/2" Dia. | 38 | 97739 | 1 | PLATE, Pump Mounting |
| 14 | B1460 | 4 | CAP, Black Vinyl | 39 | 30209 | 4 | HHCS, 5/16" - 24 x 1 1/4" |
| 15 | B2759 | 1 | HOOK, Square Neck Gun | 40 | B3468B | 1 | ASSY., PUMP EG Horizontal |
| 16 | A1041 | 1 | FILTER, Chemical Hose | 41 | 21424 | 1 | CONNECTOR, Garden Hose |
| 17 | B1779 | 2 | COVER, Hinge | 42 | A1408 | 1 | CAP, Garden Hose Connector |
| 18 | AB2534 | 1 | HANDLE, Vertical | 43 | B1880 | 3 | NUT, M8 with Washer |
| 19 | B2071 | 2 | NUT, Locking Flange 1/4" - 20 | 44 | 48031G | 2 | CLAMP, Hose 3/16" Band |
| 20 | 21217 | 4 | MOUNT, Rubber Shock | 45 | A1040A | 1 | HOSE, Chemical 42" Clear |
| 21 | B2347 | 2 | CAP, End of Tube | 46 | 97100 | 1 | CAP, High Pressure Adapter |
| 22 | 31669 | 1 | CARRIAGE BOLT, 1/4" - 20 x 1-3/4" | 47 | 98300 | 1 | SEAL, Engine Donut |
| 23 | B3107 | 1 | HOSE, Thermal Drain | 48 | B2218 | 2 | O-RING, 1.625" I.D. x .103" |
| 24 | 48031B | 1 | CLAMP, Hose 3/8" Band | 49 | NSP | 1 | ENGINE, Honda 5HP |
| 25 | B3607 | 1 | HOSE, 1/4" x 25' | 50 | 67989 | 8 | NUT, M8 Flange Serr. |
| | | | | 51 | 21761 | 1 | NOZZLE, 1.05 Yellow Replacement |

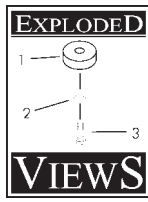

EXPLODED VIEW-PUMP

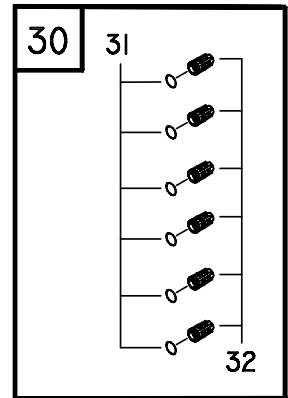
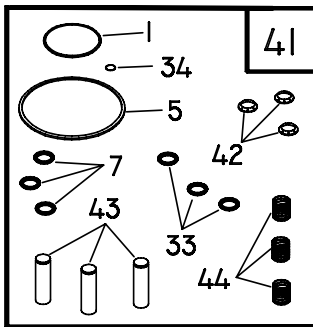
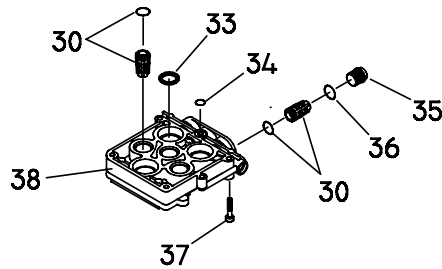
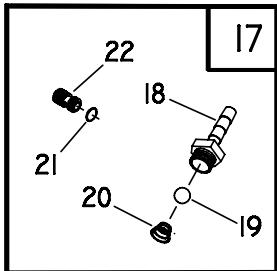
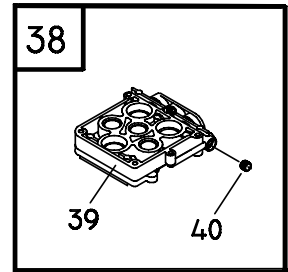
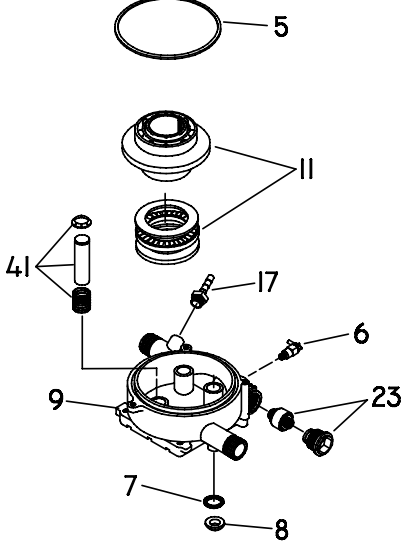
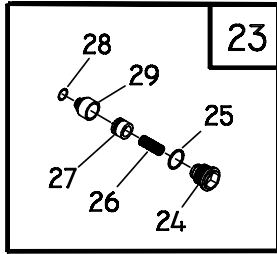
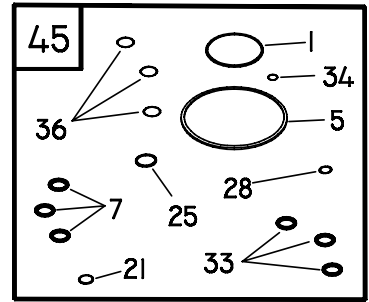
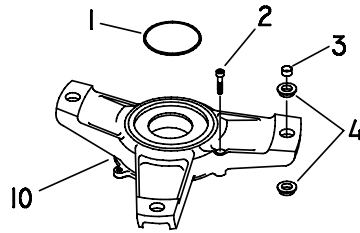
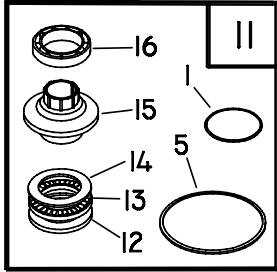

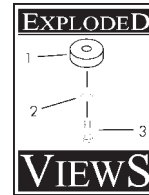

PART LIST-PUMP

| Item | Part # | Qty | Description | Item | Part # | Qty | Description |
|------|--------|-----|-----------------------------|------|--------|-----|------------------------------|
| 1 | 98300 | 1 | SEAL, Engine Donut | 30 | B3513 | 0 | KIT, CHECK VALVES |
| 2 | 97962 | 3 | SHCS, M6 - 1 x 25 | 31 | | 6 | O-RING, Check Valve |
| 3 | 96795 | 3 | SLEEVE, Grommet Spacer | 32 | | 6 | ASSY., Check Valve |
| 4 | 21429 | 6 | BUSHING, Rubber Mount | 33 | B3286 | 3 | SEAL, Double-Lip |
| 5 | 97835 | 1 | O-RING, Housing Seal | 34 | 97837 | 1 | O-RING, Hi-Pressure Transfer |
| 6 | B3090 | 1 | THERMAL RELIEF, GPW-EG | 35 | 97841 | 3 | CAP, Outlet Check Valve |
| 7 | 93680 | 3 | SEAL, Oil Piston 15 TC4 | 36 | 97840 | 3 | O-RING, Outlet CV Cap |
| 8 | 97831 | 3 | SPACER, Pilot | 37 | 40946 | 4 | SHCS, M6-1.0 x 35 |
| 9 | B2702 | 1 | HOUSING, Piston | 38 | B4186 | 0 | KIT, HEAD CASTING SFG |
| 10 | 98227 | 1 | ADAPTER, Engine | 39 | | 1 | HEAD, Pump |
| 11 | B4337 | 0 | KIT, AXIAL CAM SERV | 40 | | 1 | PLUG, 1/8-28 W/VIBR |
| 12 | | 1 | WASHER, Brg. 36 x 65 x 6Thk | 41 | B2312 | 0 | KIT, PISTON & SPRING |
| 13 | | 1 | ASSY., Brg. Cage 45 x 65 | 42 | | 3 | RETAINER, Piston Spring |
| 14 | | 1 | WASHER, Brg. 45 x 65 x 1 | 43 | | 3 | PISTON, Dia. 15 x 65 Lg |
| 15 | | 1 | CAM, Axial 5.6 HS | 44 | | 3 | SPRING, Piston Return |
| 16 | | 1 | BALL BEARING, 35 x 72 x 17 | 45 | B1933 | 0 | KIT, O-RING/SEAL SERV |
| 17 | B3829 | 0 | KIT, CHEM INJECT | 1 | | 1 | SEAL, Engine Donut |
| 18 | | 1 | FITTING, Chem Inject | 5 | | 1 | O-RING, Housing Seal |
| 19 | | 1 | BALL, Chem Inject | 7 | | 3 | SEAL, Oil Piston 15 TC4 |
| 20 | | 1 | SPRING, Chem Inject | 21 | | 1 | O-RING, Venturi |
| 21 | | 1 | O-RING, Venturi | 25 | | 1 | O-RING, Unloader Cap |
| 22 | | 1 | VENTURI, Chem Inject | 28 | | 1 | O-RING, .364ID x .070 |
| 23 | B3828 | 0 | KIT, UNLOADER | 33 | | 3 | SEAL, Double-Lip |
| 24 | | 1 | CAP, Unloader | 34 | | 3 | O-RING, Outlet CV Cap |
| 25 | | 1 | O-RING, Unloader Cap | | | | |
| 26 | | 1 | SPRING, 2000 Unloader | | | | |
| 27 | | 1 | PISTON, Unloader | | | | |
| 28 | | 1 | O-RING, .364 ID x .070 | | | | |
| 29 | | 1 | SEAT, 2000 Unloader | | | | |

Item numbers 11, 17, 23, 30, 38, 41, and 45 are service kits and include all parts shown within the box. Items previously described are not listed under the service kit number.

LIMITED PRESSURE WASHER WARRANTY

Generac Portable Products LLC (hereafter referred to as GENERAC LLC) warrants to the original retail purchaser, the pressure washer manufactured by GENERAC LLC to be free from defects in material and workmanship for the period(s) set forth below from the date of original purchase. This warranty is not transferable. The term "original purchaser" means the person for whom the pressure washer is originally purchased.

Warranty Schedules

| | | | |
|-------------------------|--|---|---|
| Electric Power Washer | 1 year (does not apply to commercial or rental applications) | | |
| All Other Engine-driven | | CONSUMER* | COMMERCIAL* |
| | Engine: | Warranted solely by Engine Manufacturer | Warranted solely by Engine Manufacturer |
| | Pump: | 1 year | 90 days |

*** NOTE: For the purpose of this warranty "consumer use" means personal residential household use by original purchaser. "Commercial Use" means all other uses, including rental, construction, commercial and income producing purposes. Once a pressure washer has experienced commercial use, it shall thereafter be considered a commercial use pressure washer for the purposes of this warranty.**

During said warranty period, GENERAC LLC will, at its option, repair or replace any part which, upon examination by GENERAC LLC or GENERAC LLC Authorized Dealers, is found to be defective under normal use and service**. All transportation costs under warranty, including return to the factory if necessary, are to be borne by the purchaser and prepaid by the purchaser.

**** NORMAL WEAR: As with all mechanical devices, pressure washers need periodic parts service and replacement to perform well. This warranty does not cover repair when normal use has exhausted the life of a part or pressure washer pump.**

This warranty does not include: Used products and demonstration equipment. Parts, such as GUNS, HOSES, WANDS, NOZZLES or other wear items such as quick couplers, oil, gauges, belts, o-rings, filters, pump packing, etc. Pumps which have been run without water supplied. Damage or malfunctions resulting from: accidents, abuse, modifications, alterations, or improper servicing. Freezing or chemical deterioration. Normal maintenance such as adjustments, fuel system cleaning and obstruction (due to chemical, dirt, carbon or lime, etc.).

THIS WARRANTY IS IN PLACE OF ALL OTHER WARRANTIES, EXPRESS OR IMPLIED, SPECIFICALLY, GENERAC LLC MAKES NO OTHER WARRANTIES AS TO MERCHANTABILITY OR FITNESS FOR A PARTICULAR PURPOSE. THE DURATION OF ANY IMPLIED WARRANTIES WHICH CANNOT BE DISCLAIMED IS LIMITED TO THE TIME PERIOD AS SPECIFIED IN THE EXPRESS WARRANTY. LIABILITY FOR CONSEQUENTIAL, INCIDENTAL, OR SPECIAL DAMAGES UNDER ANY AND ALL WARRANTIES IS EXCLUDED, EVEN IF SUCH DAMAGES ARE A DIRECT RESULT OF GENERAC LLC'S NEGLIGENCE. GENERAC LLC ALSO DISCLAIMS ANY RESPONSIBILITY FOR INCIDENTAL OR CONSEQUENTIAL DAMAGES SUCH AS THE LOSS OF TIME OR THE USE OF THE POWER EQUIPMENT, OR ANY COMMERCIAL LOSS DUE TO THE FAILURE OF THE EQUIPMENT: AND ANY IMPLIED WARRANTIES ARE LIMITED TO THE DURATION OF THIS WRITTEN WARRANTY.

Some states do not allow limitations on how long an implied warranty lasts, or the exclusion or limitation of incidental or consequential damages, so the above limitations or exclusions may not apply to you. This warranty gives you specific legal rights and you may also have other rights, which vary from state to state.

For service, see your nearest GENERAC LLC authorized warranty service facility or call 1-877-544-0982. Warranty service can be performed only by a GENERAC LLC authorized service facility. This warranty will not apply to service at any other facility. At the time of requesting warranty service, evidence of original purchase date must be presented.

Generac Portable Products LLC

Jefferson, Wisconsin U.S. A.